

**NEW**



**SITE DUMPERS** | 1T-2, 3T-2, 6T-2, 9T-2

Payload: 1000 – 9000kg





# THE INDUSTRY'S SAFEST DUMPER RANGE.

The new JCB Site Dumper range has been designed to meet the needs of both rental customers and contractors alike, driving positive change within the industry.

Comprising of a range of machines between one and nine tonnes, they provide industry-leading levels of safety as standard. Included in the range are innovative features such as the SiTESAFE cab, which is tested to withstand the impact from a 20 tonne Excavator; and SiTESAFE skip providing exceptional visibility. In-house design, manufacture and testing provide you with the peace of mind that operator safety is our number one priority.

Whatever your business, JCB site dumpers can make a positive difference; offering more safety, productivity and serviceability than ever before.









## THE INDUSTRY'S SAFEST.

OPERATOR AND SITE SAFETY ARE AT THE CORE OF JCB SITE DUMPERS. THROUGH EXTENSIVE RESEARCH AND DEVELOPMENT, JCB HAS INTRODUCED A UNIQUE RANGE OF SMART SAFETY FEATURES AND DESIGNED BOTH THE SITESAFE CAB AND SKIP, MAKING THE STAGE V RANGE THE SAFEST IN THE INDUSTRY.

**JCB**  
SITESAFE

The skip doesn't compromise on dimensions, matching the length, turning circle and ground clearance of a conventional site dumper.

In response to industry feedback a new lower overall height improves access into the cab and improves stability, due to a lower centre of gravity on the 9T-2.

The SITESAFE skip design improves forward visibility by up to 30%, when compared to a conventional front tip skip.

## Industry-leading visibility.

- 1** Hi-Viz step and grab handles are available, to reduce likelihood of slips, trips and falls.
- 2** Green and amber LED beacons are now fitted as standard, for improved site safety.
- 3** LED work lights allow the machine and operator to carry on working, even in the toughest conditions.
- 4** Initial movement alarm warns pedestrians and other machines on site when the machine is about to move.
- 5** Both doors have lockback and ajar stays, to provide increased ventilation and improve communication on site.



## Industry-leading safety.

- 6** All SITESAFE cabs are fitted with Hammerglass™ impact protective front screen and toughened side and rear glass as standard.
- For additional protection, there is a front screen guard option.
- 7** Designed and tested to withstand the impact from a 20T excavator, ensuring operator safety on site.
  - 8** Standard heater and optional chiller system means you can adjust the in-cab temperature, no matter the ambient conditions. This maximises operator comfort and productivity.
  - 9** Two stage Drive Inhibit system ensures the operator wears a seat belt during machine operation.





# PRODUCTIVITY AND PERFORMANCE.

YOU CAN BE SAFE IN THE KNOWLEDGE THAT A JCB SITE DUMPER OFFERS SUPERIOR PRODUCTIVITY & RELIABILITY. THE COMPLETE RANGE IS DESIGNED TO MAKE THE MOST EFFICIENT USE OF YOUR TIME AND MONEY, MAKING A HUGE DIFFERENCE TO YOUR BUSINESS.

## The JCB advantage.

The 1T-2 and the 3T-2 have no requirement for after treatment, maximising machine uptime. The 6T-2 and 9T-2 are fitted as standard with auto regeneration technology.

A choice of high-tip, front tip and swivel tip, ensures suitability of the JCB range for various applications.



Auto DPF results in zero downtime on-site. Requiring no input from the operator, the machine will self-regulate.

Improved cold start capability, thanks to new pre-heat system.

Service intervals extended to 1000 hours, letting your machine spend more time working with less downtime.

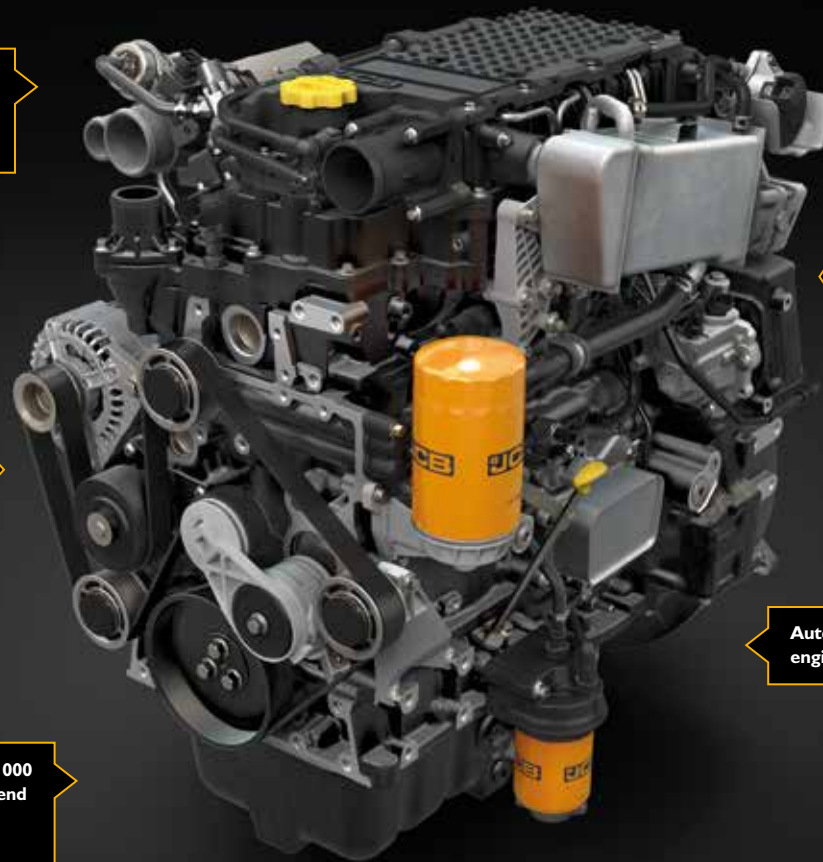

Designed to work in conjunction with JCB Axles and Transmission, no other dumper is built this way.

Auto stop function will stop the engine after a set period of time.

New JCB 430 55kW Engine.

**STAGE V**



The new JCB 430 engine has a 10% increase in torque improving laden and hill climb performance.



# BUILT FOR RENTAL RETURNS.

IF IT'S IMPORTANT TO YOUR BUSINESS, IT'S IMPORTANT TO JCB. THAT'S WHY JCB SITE DUMPERS HAVE BEEN DESIGNED, DEVELOPED AND BUILT TO WITHSTAND THE RIGOURS OF THE RENTAL INDUSTRY. TRIED AND TESTED COMPONENTS AND WORLD-CLASS MANUFACTURING STANDARDS, ENSURE MAXIMUM MACHINE UPTIME AND SERVICE LIFE.

## Secure your investment.

**1** Rental customers have access to industry-leading dealer and parts support, via the JCB dealer network. They can deliver 95% of all parts anywhere in the world within 24 hours, to maximise machine uptime and your return on investment.

LiveLink telematics helps you monitor and manage your fleet's condition, location and activity, remotely, 24/7 via the web:

- › Machine security alerts
- › Machine safety alerts
- › Machine service and maintenance alerts

**2** Multiple, well positioned tie down points helps with easy and safe transportation between sites.

## Built to last.

**3** The new JCB site dumper range has undergone a stringent testing programme, including prolonged high stress loading of the chassis, skip and other key components. Cold climate testing and repeated use over thousands of cycles has also been implemented.

All JCB site dumpers are designed for heavy duty washing with a quick turnaround. New relay protection on 6T and 9T machines prevents water ingress to key electrical components during washing and adverse weather conditions.







Our industry leading factory fit telematics gives you the information to proactively improve efficiency, safety and uptime, giving your fleet the JCB advantage.



## GREATER SERVICEABILITY.

TO MAKE THE MOST OF YOUR INVESTMENT, YOU NEED YOUR SITE DUMPER TO SPEND ITS TIME WORKING, NOT BEING WORKED ON. THAT'S WHY THE 1-3 TONNE MODELS HAVE NO REQUIREMENT FOR AFTER TREATMENT, WHILE THE LARGER MACHINES HAVE SMART DPF REGENERATION. WHEN MAINTENANCE DOES NEED TO BE CARRIED OUT, ITS QUICK AND EASY TO PERFORM.

### Straightforward servicing.

**1** Daily checks are simple with ground level access to all main service areas. A tilting seat base on the 1T-2 and 3T-2 models allows for uncompromised service access to the engine, making it easier to reach dipsticks and fluid fill points.

Floor panels on all models can be removed without a specialist tool to access more of the machine for necessary maintenance.

For added peace of mind, all site dumpers come with a 2-year warranty as standard.

JCB Service can work on all machines avoiding third-party call outs.

**2** LiveLink telematics is available on all JCB Site Dumpers. LiveLink is standard for 6T-2 & 9T-2 for two years and provides real-time access to DPF information and other key serviceable parts and fluids.

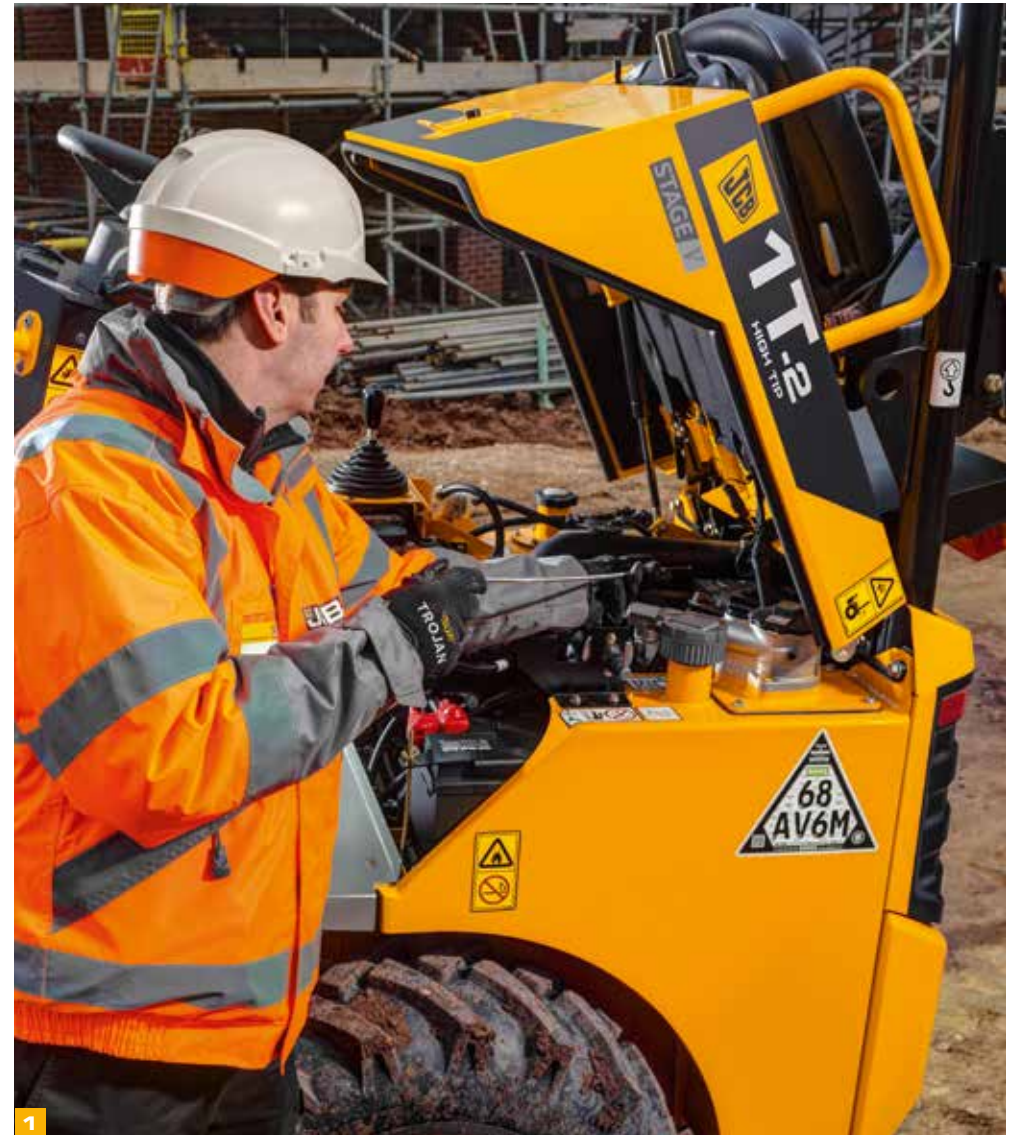





**Our industry leading factory fit telematics helps you to proactively check efficiency, operating time and plan maintenance, giving your fleet the JCB advantage.**



## IT-2 SITE DUMPER.

BUILT WITH TOTAL SAFETY IN MIND, THE IT-2 INCLUDES MARKET-FIRST INNOVATIONS SPECIFICALLY DESIGNED TO ADDRESS INDUSTRY CONCERNS. THE RESULT IS A MACHINE WITH UNRIVALLED SAFETY, DURABILITY AND SERVICEABILITY. A MACHINE PERFECT FOR RENTAL FLEETS AND CONTRACTORS.



### The industry's safest.

With a new 16.1kW Perkins Stage V compliant engine, the new machine now has 21% more torque compared to the outgoing model.

- 1 The High-Tip feature makes it possible to tip into skips and large containers.
- 2 The intuitive "stop and go" pedal controls the hydrostatic drive, making the machine easy to operate for novices and experienced operators alike.
- 3 Thanks to its compact design, the IT-2 can work safely in confined areas. Also, with the optional narrow tyres fitted, the machine has a sub 1m overall width, allowing it to fit through doorways.







Key immobiliser for theft prevention.

Tilt warning system notifies the operator when they are reaching the limits of the machine, through visual and audible alerts.

Engine tip-over protection, prevents engine damage in the event of machine tip-over.

Wide track wheels improve stability by 16%.

JCB has recognised the industry-wide safety concerns surrounding IT dumpers and has worked tirelessly with industry experts to offer a solution.



## 3T-2 SITE DUMPER.

WITH SAFETY AS STANDARD, THE 3T-2 HAS BEEN DESIGNED TO SUIT MULTIPLE APPLICATIONS, FROM LANDSCAPING TO UTILITIES WORK, MAKING IT IDEAL FOR THE RENTAL MARKET.

360° engine access makes completing daily checks and servicing easy.



### Adaptable and dependable.

**1** The 3T-2 Site Dumper has a new 18.9kW Stage V compliant engine with no DPF resulting in reduced downtime. The combination of hydrostatic drive and 87.2Nm of torque at 1800rpm ensures excellent gradient performance.

**2** Unique drive inhibit feature prevents the operator using the machine without wearing a seatbelt. To further improve safety, a seatbelt monitoring green beacon is now fitted as standard.

**3** Front or Swivel tip option is available to suit different applications.

To negate the requirement for a trailer, the 3T-2 is available with an optional road light kit allowing the machine to travel between work sites independently.

Optional high-visibility steps and grab handles provide easier and safer access and egress.



1



2



3





**Ergonomic transmission dump switch allows the operator to divert the full power of the engine from the transmission to the hydraulic system, increasing performance.**



## 6T-2 SITE DUMPER.

THE 6T-2 SITE DUMPER IS THE SAFEST AND MOST PRODUCTIVE MACHINE IN ITS CLASS. WITH A SPECIFICALLY DESIGNED JCB DRIVETRAIN, AND 3 DIFFERENT SKIP VARIANTS ON OFFER, YOUR BUSINESS CAN TRUST IN JCB TO GET THE JOB DONE.

### Unrivalled safety.

- 1 The JCB SiTESAFE cab on the 6T machine provides the operator safety and comfort.
- 2 An initial movement alarm warns people in the surrounding area of the machine. An optional object detection system alerts the operator to any objects near to the machine, preventing accidents and damage, whilst in operation.
- 3 The front tip and swivel tip machines come with a front mounted camera as standard to comply with visibility standards. Additionally, there is the option of upgrading to the full side and rear camera kit, further improving visibility and safety.

For even greater operator protection, an optional skip guard prevents large pieces of material falling out of the back of the skip.

- 4 As an alternative to the standard ROPS frame, a ROPS/FOPS Level II frame is available, providing a greater level of safety for the operator. JCB SiTESAFE cab offers even greater levels of safety.







Due to optimal skip geometries the 6T-2 can be loaded by a variety of machines with ease.



## 9T-2 SITE DUMPER.

FOR THE ULTIMATE BALANCE OF SAFETY, COMFORT AND MASS MATERIAL MOVEMENT, YOU CAN TRUST IN THE 9T-2. THE NEW SITESAFE SKIP PROVIDES BEST IN CLASS FORWARD VISIBILITY, WITHOUT COMPROMISE.

### Efficient engine design.

**1** The new 430 Stage V compliant 55kW engine produces 10% more torque compared to the previous model, as well as lower emissions. And with new improved cold start performance, the 9T-2 will carry on performing even in the harshest conditions.

**2** Rear road lights can be folded away on site to prevent damage.

**3** Optional LED work lights allow the machine and operator to carry on working even in the toughest conditions and to further improve machine visibility on site, and LED beacons are fitted as standard.

An optional white noise reverse alarm allows the machine to operate in noise sensitive areas.

Optional flexible lower steps, prevent damage when impacted.







The SiTESAFE skip gives the driver direct line-of-sight visibility without the need for a camera.

The 6T and 9T machines are both available with front tip and SiTESAFE skip variants. In addition, the 6T model has a 3rd option of a swivel tip skip.





## LIVELINK TELEMATICS.

LiveLink telematics helps you monitor and manage your machine fleet remotely anywhere in the world by radically improving the efficiency, productivity, safety and security of all your JCB and non JCB machine fleet.

**MACHINE EFFICIENCY:** Keep track of your machine's daily activity with regular performance reports which provide information about idle time, location, machine health, error codes for diagnostics, engine utilisation by power band, safety alerts, and fuel consumption. JCB LiveLink ensures machines are kept running for maximum uptime and return on investment.

**MACHINE RELIABILITY:** Accurate hours and service alerts improve maintenance planning to optimise machine productivity.

**MACHINE SECURITY:** LiveLink's real time geo-fencing alerts tell you when machines move out of predetermined zones. Curfew alerts inform you of unauthorised usage.



Track the location of any asset via Bluetooth connection.



An after market telematics solution which can be retrofitted to any machine.



## COMPLETE CONTROL FOR YOUR FLEET.

LiveLink Fleet enables you to track every aspect of your equipment to maximise efficiency and machine uptime.

**GUESS LESS, KNOW MORE:** Equipment issues and service reminders are logged as soon as they occur, helping you to react quickly.

**YOUR EYES ON THE GROUND:** Integrate LiveLink Fleet with the JCB Operator mobile app and data from your operators' daily equipment checks feed instantly into your dashboard.

**TOTAL PEACE OF MIND:** Operator safety alerts help to ensure machines are being used efficiently and safely.

**SMARTER TOOLS. SMARTER DECISIONS:** From hours worked to fuel wastage, access custom analytics on your fleet to make smarter decisions, quicker.

**EFFORTLESS MEETS PAPERLESS:** Access certificates, warranty information, quick start machine guides and manuals.

## The Operator app

### THEY SPOT IT, YOU KNOW IT.

The JCB Operator app gives you faster, clearer and more accurate information about your fleet, direct from the people using your equipment each day.

**STAY IN TOUCH:** Get regular checks on your machine with visibility in the LiveLink Fleet portal.

**TAILOR YOUR CHECKS:** Customise your checklists to suit any application, customer or site.

**UPLOAD TO KEEP UPDATED:** Upload useful information with photos and comments.

**FULLY COMPATIBLE:** The JCB Operator app works with non telemetry related machines and assets.

**ACCESS ALL INFORMATION:** Get access to documentation such as quick start guides.

\*The individual features of LiveLink Telematics, LiveLink Fleet and Operator App vary per region, engine and machine type.



## FULLY SUPPORTED.

JCB'S WORLDWIDE CUSTOMER SUPPORT IS FIRST CLASS. WHATEVER YOU NEED AND WHEREVER YOU ARE, WE'LL BE AVAILABLE QUICKLY AND EFFICIENTLY TO HELP MAKE SURE YOUR MACHINERY IS PERFORMING TO ITS FULL POTENTIAL.



1

1 Our Technical Support Service provides instant access to factory expertise, day or night, while our Finance and Insurance teams are always on hand to provide fast, flexible, competitive quotes.

2 The global network of JCB Parts Centres is another model of efficiency; with 18 regional bases, we can deliver around 95% of all parts anywhere in the world within 24 hours. Our genuine JCB parts are designed to work in perfect harmony with your machine for optimum performance and productivity.



2

3 JCB offers comprehensive extended warranties as well as service-only or repair and maintenance contracts. Irrespective of what you opt for, our Maintenance teams around the world charge competitive labour rates, and offer non-obligation quotations as well as fast, efficient insurance repair work.



3

Note: JCB LIVELINK and JCB extended warranty packages may not be available in your region, so please check with your local dealer.

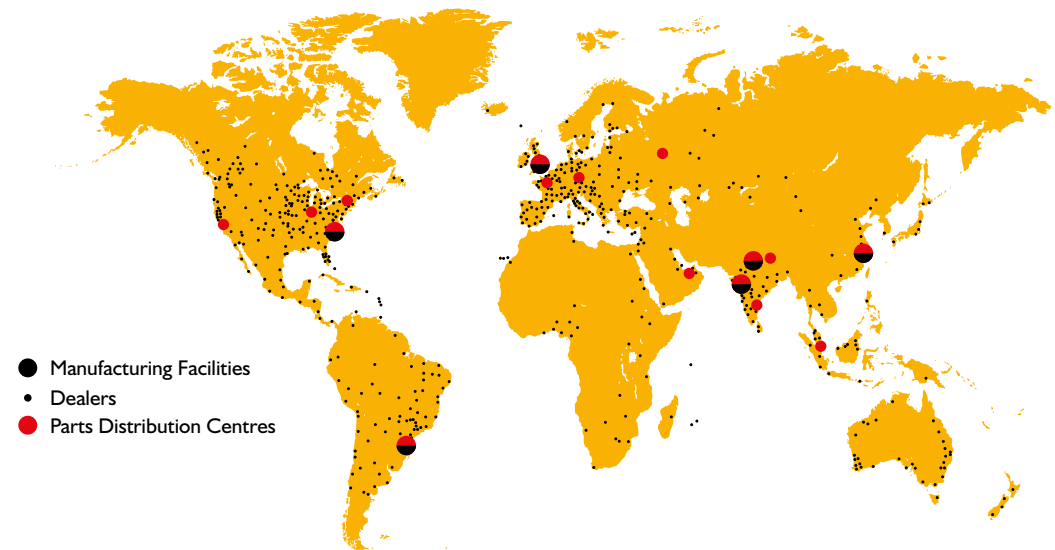



STATIC DIMENSIONS AND CAPACITIES

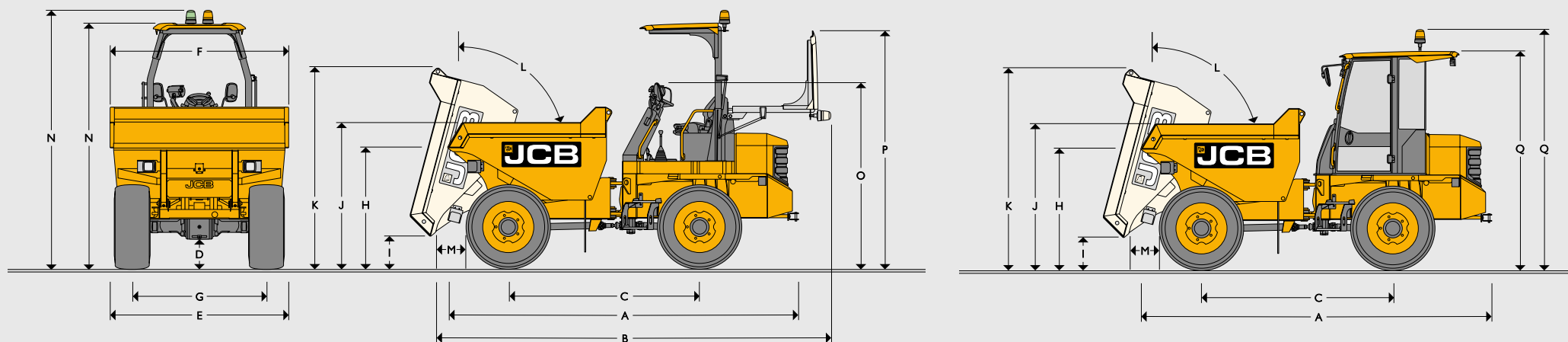

STATIC DIMENSIONS AND CAPACITIES

		1T-2 HT	3T-2 FT	3T-2 ST	6T-2 FT	6T-2 ST	6T SiTESAFE Skip	9T-2 FT	9T SiTESAFE Skip
A	Overall length	mm	3095	3758	3926	4792	5047	4771	4918
B	Overall length (ROPS or FOPS folded)	mm	3403	4192	4360	5023	5280	5011	5158
C	Wheelbase	mm	1500	1950	1950	2480	2480	2680	2880
D	Minimum ground clearance	mm	263	206	206	312	312	316	359
E	Total width (Standard/Narrow tyres)	mm	1106/980	1650	1650	2255	2255	2300	2380
F	Skip width	mm	980	1650	1654	2310	2018	2300	2500
G	Track width (Standard/Narrow tyres)	mm	850/782	1360	1360	1850	1850	2225	1880
I	Height to front lip of skip (untipped)	mm	1134/2259	1367	1467	1672	1719	1523	1732
H	Height to front lip of skip (tipped)	mm	452/1573	306	856	310	1122	508	415
J	Load over height	mm	1268/2392	1504	1567	1791	2028	2150	2001
K	Height over skip (tipped)	mm	1865/3037	2085	2860	2411	3674	2456	2680
L	Skip tip angle	Degrees	90	75	67	80	70	75	80
M	Discharge distance front	mm	391	568	548	604	582	580	526
	Discharge distance side	mm	N/A	N/A	319	N/A	241	N/A	N/A
	Turning radius to outside of skip	mm	2712	5448	4573	5900	5777	5645	6372
	Turning radius to outside of tyres	mm	2559	4464	4464	5755	5739	5526	6218
	Steering angle (+/-)	Degrees	39	30	30	30	30	34	30
	Oscillation	Degrees	15	10.5	10.5	10	10	10	10
N	Height to top of ROPS (with/without beacon)	mm	2792/2602	3016/2835	3016/2835	3354/3131	3354/3131	3354/3131	3570/3347
N	Height to top of ROPS/FOPS (with/without beacon)	mm	N/A	N/A	N/A	3354/3169	3354/3169	3354/3169	3570/3385
O	Height with folded ROPS	mm	1624	1857	1857	2169	2169	2013	2319
P	Height with folded ROPS/FOPS	mm	N/A	N/A	N/A	2936	2936	2936	3154
Q	Height to top of cab (with/without beacon)	mm	N/A	N/A	N/A	3296/3014	3296/3014	3296/3014	3512/3230

\*With high tip mechanism raised.



CAPACITIES									
		1T-2 HT	3T-2 FT	3T-2 ST	6T-2 FT	6T-2 ST	6T SiTESAFE Skip	9T-2 FT	9T SiTESAFE Skip
Payload	kg	1000	3000	3000	6000	6000	6000	9000	9000
Operating weight - ISO6016 full tank of fuel & 75kg operator (ROPS)	kg	1515	2345	2390	4840	5070	5040	5400	5085
Operating weight - ISO6016 full tank of fuel & 75kg operator (ROPS/FOPS)	kg	N/A	N/A	N/A	4920	5150	4960	5480	5165
Operating weight - ISO6016 full tank of fuel & 75kg operator (Cab)	kg	N/A	N/A	N/A	5180	5410	5220	5740	5425
Tipping type		Front tip - high tip	Front tip	Swivel tip	Front tip	Swivel tip	Front tip	Front tip	Front tip
Skip Capacity (fluid)	l	307	1050	930	1974	1615	1900	2435	2170
Skip Capacity (struck)	l	454	1420	1237	2537	2514	2725	3735	3720
Skip capacity (heaped)	l	554	1723	1615	3191	3149	3300	4531	4300

ENGINE									
		1T-2 HT	3T-2 FT	3T-2 ST	6T-2 FT	6T-2 ST	6T SiTESAFE Skip	9T-2 FT	9T SiTESAFE Skip
Engine model		Perkins 403J.II	Perkins 403J-17		JCB DieselMAX				
Capacity	cc	1131	1662		3000				
Aspiration		Naturally Aspirated	Naturally Aspirated		Turbocharged				
Cylinders		3	3		4				
Max. gross power to SAE J1995/ISO 14396	kW (hp)	16.1 (21.6)	18.9 (25.3)		55 (74)				
Max. torque	Nm	66.8	87.2		440				
Emissions compliance		EU Stage V / Tier 4 Final	Stage V		Stage V				

TRANSMISSION									
		1T-2 HT	3T-2 FT	3T-2 ST	6T-2 FT	6T-2 ST	6T SiTESAFE Skip	9T-2 FT	9T SiTESAFE Skip
Type		Hydrostatic pump to 4 hydraulic wheel motors	Hydrostatic motor via transfer box to front and rear axles		Powershuttle				
Tyre size		"255/75 x 15.3 x 8 ply (option 7.0 x 12 narrow tyre)"	295/80 x 15.3 (10 ply)		405-70-20 14PR			500-60-22.5 16PR	
Drive		Hydrostatic I/I	"2/2 (High and low range - forward and reverse) Hydrostatic - permanent 4WD"		4/4 Forward and reverse - permanent 4WD				
Max. travel speed (unladen) 1st gear	mph (kph)	7.4 (11.9)	5.0 (8) - Tortoise		3.1 (5.0)			2.8 (4.5)	
Max. travel speed (unladen) 2nd gear	mph (kph)	-	13 (21) - Hare		5.0 (8.1)			4.7 (7.5)	
Max. travel speed (unladen) 3rd gear	mph (kph)	-	-		9.4 (15.2)			8.8 (14.1)	
Max. travel speed (unladen) 4th gear	mph (kph)	-	-		15.9 (25.6)			15.3 (24.7)	



**ELECTRICAL SYSTEM**

		1T-2 HT	3T-2 FT	3T-2 ST	6T-2 FT	6T-2 ST	6T SiTESAFE Skip	9T-2 FT	9T SiTESAFE Skip
System voltage	V				12				
Alternator output	A	40	65				95		
Battery capacity	Ah	80	62				110		

**SERVICE FILL CAPACITIES**

		1T-2 HT	3T-2 FT	3T-2 ST	6T-2 FT	6T-2 ST	6T SiTESAFE Skip	9T-2 FT	9T SiTESAFE Skip
Hydraulic tank	l	28	35				60		
Fuel tank	l	30	35				65		

**BRAKING**

		1T-2 HT	3T-2 FT	3T-2 ST	6T-2 FT	6T-2 ST	6T SiTESAFE Skip	9T-2 FT	9T SiTESAFE Skip
Working brake		Hydrostatic dynamic braking on rear wheel motors	Multi-plate in-board oil immersed discs on front axle				Foot brake-oil immersed discs on front/rear		
Parking brake		Hydrostatic dynamic braking on rear wheel motors	Over centre handbrake-oil immersed discs on front axle				Over centre parking brake-dry disc on gearbox		



OPTIONS	1T-2	3T-2	6T-2	9T-2
Folding ROPS frame	●	●	●	●
Folding ROPS/FOPS Lvl II frame	■	■	+	+
JCB SITESAFE Cab (ROPS/FOPS Level II) with heater and protective front screen	■	■	+	+
JCB SITESAFE Cab (ROPS/FOPS Level II) with heater, air cooling and protective front screen	■	■	+	+
Front Screen Guard (Only available with Cab)	■	■	+	+
Skip Guard	■	■	+	+
Reverse alarm	●	●	●	●
White Noise reverse alarm	+	+	+	+
Dual circuit breaking	■	■	●	●
Speedometer	■	■	●	●
Tie-down and lifting points	●	●	●	●
Lap belt (high-visibility orange, emergency locking retractor)	●	●	●	●
LED amber beacon	●	●	●	●
LED green beacon	●	●	●	●
Sequenced drive inhibit system	●	●	●	●
Audible alarm on initial machine movement (horn sounds twice)	●	●	●	●
Skip raised audible alarm	■	■	+	+
Seat adjustment: fore/aft, operator weight, back angle	●	●	●	●
Recovery hitch	■	●	●	●
Tow bar	■	■	+	+
Full width steering column protection	●	●	●	●
CESAR Datatag security (UK only)	●	●	●	●
Traction tyres	●	●	●	●
Narrow tyres	+	■	■	■
Wide Track	+	■	■	■
Turf tyres	■	■	+	■
High visibility steps and grab handles	+	+	+	+
Flexible steps	■	■	+	+
Rear view mirrors	+	+	+	+
Road lights	+	+	+	+
LED work lights (front and rear)	+	+	+	+
Three speed only restriction	■	■	+	+
Object detection system (requires front camera fitment)	■	■	+	+
Front Camera (Not standard on SITESAFE skip variants)	■	■	●	●
Side/Rear Cameras (requires front camera fitment)	■	■	+	+
LiveLink telematics	+	+	●	●
Rental ready decals - clear skip sides	+	+	+	+
Front bumper bar	+	■	■	■
Loose decals	■	+	+	+
Spare tyre	+	+	+	+
SMART Safety pack	+	■	■	■

- Standard
- + Option
- Not available













**ONE COMPANY, OVER 300 MACHINES.**

Your nearest JCB dealer

### Site Dumpers

IT-2, 3T-2, 6T-2, 9T-2  
 Payload: 1000 – 9000kg

JCB Sales Limited, Rocester, Staffordshire, United Kingdom ST14 5JP.  
 Tel: +44 (0)1889 590312 Email: [salesinfo@jcb.com](mailto:salesinfo@jcb.com)  
 Download the very latest information on this product range at: [www.jcb.com](http://www.jcb.com)

©2009 JCB Sales. All rights reserved. No part of this publication may be reproduced, stored in a retrieval system, or transmitted in any form or by any other means, electronic, mechanical, photocopying or otherwise, without prior permission from JCB Sales. All references in this publication to operating weights, sizes, capacities and other performance measurements are provided for guidance only and may vary dependant upon the exact specification of machine. They should not therefore be relied upon in relation to suitability for a particular application. Guidance and advice should always be sought from your JCB Dealer. JCB reserves the right to change specifications without notice. Illustrations and specifications shown may include optional equipment and accessories. The JCB logo is a registered trademark of J C Bamford Excavators Ltd.

